



OVER **35** YEARS OF SERVICE.
YOUR LEGAL INFORMATION SOURCE!

Co-sponsored with the Professional Liability Committee and the Solo & Small Firm Section of the Colorado Bar Association

HANGING YOUR SHINGLE 2009 -

BY CHOICE OR CIRCUMSTANCE

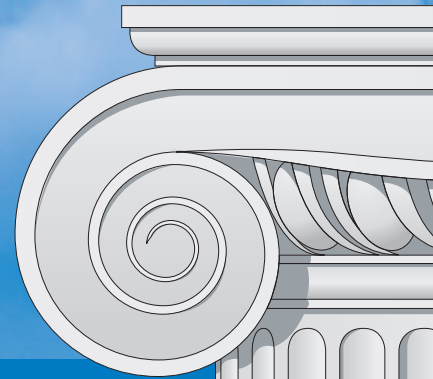

The CBA Economic Assistance Task Force is offering special pricing for CBA MEMBERS affected by the economy!

LIVE PROGRAM AND LIVE WEBCAST: AUGUST 13-14, 2009

Live program will be held at the CBA-CLE Classroom, 1900 Grant Street, Suite 300, Denver, CO

VIDEO REPLAYS: SEPTEMBER 2-3, 2009 • Denver, Colorado Springs, and Grand Junction

TOPICS TO BE COVERED:

- Is Solo Practice or Starting a Small Firm For You?
- Other Business Arrangements - How To Choose
- Choice of Entity for Practice
- Technology is Your Best "Partner"
- Bookkeeping and Recordkeeping - When Will I Have Time?
- Marketing and Business Development - the Ying/Yang of Growing your Business
- Office Sharing - Nuts, Bolts and Paperclips
- Practice Maintenance
- Make A Business Plan
- Risky Business - Managing Your Malpractice Exposure
- Practical Application of the Rules of Professional Conduct
- Success Stories of Opening Your Own Law Practice

**A TWO-DAY
INTENSIVE WORKSHOP
ON OPENING YOUR
OWN LAW FIRM!**

Submitted for 15 General Credits, including 3 Ethics

HANGING YOUR SHINGLE 2009 - BY CHOICE OR CIRCUMSTANCE

Co-sponsored with the Professional Liability Committee and the Solo & Small Firm Section of the Colorado Bar Association

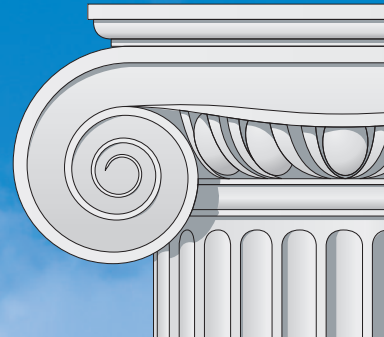

LIVE PROGRAM AND LIVE WEBCAST: **AUGUST 13-14, 2009**

Live program will be held at the
CBA-CLE Classroom,
1900 Grant Street, Suite 300, Denver, CO

VIDEO REPLAYS:

SEPTEMBER 2-3, 2009

Denver, Colorado Springs, and Grand Junction

***Submitted for 15 General Credits,
including 3 Ethics***

Law School taught you how to think like a lawyer, but how do you start or run your own legal practice? If you are considering "hanging your shingle" or transitioning to your own law firm - don't miss this valuable two-day program!

Seasoned and recently solo practitioners will address hundreds of issues faced in the creation of a new practice, including formulating a realistic business plan, the nuts and bolts of setting up your office, acquisition and effective usage of technology, marketing your practice, managing billing and avoiding malpractice. You will take home extensive course materials which provide checklists, forms and articles necessary for every practitioner.

***THIS WILL BE A POPULAR PROGRAM.
ATTENDANCE IS LIMITED - REGISTER TODAY!***

FACULTY:

David C. Little, Esq. - Program Chair
Montgomery Little Soran & Murray PC
Greenwood Village CO

Mark Beese
Leadership for Lawyers LLC
Evergreen, CO

Erich L. Bethke, Esq.
Canges Iwashko Bethke & Bailey PC
Denver, CO

Marco Chayet, Esq.
Chayet & Danzo, LLC
Denver, CO

Frank Danzo, Esq.
Chayet & Danzo, LLC
Denver, CO

David J. Graf, Esq.
Moeller Graf, PC
Englewood, CO

Robert Keatinge, Esq.
Holland & Hart LLP
Denver, CO

Reba Nance
Director of Law Practice Management
Colorado Bar Association
Denver, CO

John M. Palmeri, Esq.
Gordon & Rees LLP
Denver, CO

Brian Popp, Esq.
Law Offices of Brian S. Popp, LLC
Denver, CO

Martha L. Ridgway, Esq.
Martha L. Ridgway, P.C.
Louisville, CO

Kristi River, Firm Administrator
Canges, Iwashko, Bethke & Bailey P.C.
Denver, CO

daphne salone
law & equity ltd
Edgewater, CO

Ronald L. Seigneur,
CPA/ABV/CFF,CFA
Seigneur Gustafson LLP
Lakewood, CO

Phil J. Shuey, Esq.
Phil J. Shuey PC
Englewood, CO

PROGRAM AGENDA • DAY 1 • THURSDAY, AUGUST 13, 2009

8:00 am Registration & Continental Breakfast

8:30 am **Welcome / Introduction**

*Presented by David C. Little, Esq. -
Program Chair and Moderator*

8:45 am **Is Solo Practice or Starting Your Own Firm For You?**

- Either By Choice or Circumstance
- Considerations Upon Starting Out
- So Many Decisions To Make
- Quality of Life
- Pro's and Con's
- Getting Your Ducks in a Row

Presented by Brian Popp, Esq.

Other Business Arrangements - How To Choose

- Office Sharing, Sole Office, Home Office
- Associating with Another/Other Attorneys
- Resources to Use
- Books to Read
- CBA Opportunities
- C.R.C.P. 1.6, 1.7, 5.2 and 7.1

Presented by Reba Nance

10:15 am **Break**

10:30 am **Choice of Entity for Practice**

- Choice of Entity
- Alternatives Available
- Importance of Your Choice
- Why Worry About It
- Tax Considerations
- Advantages and Obligations
- CRCP 265
- CRPC 5.4
- Partnership and Operating Agreements

Presented by Robert Keatinge, Esq.

11:15 am **Technology Is Your Best Partner**

- What Will You Need and What Does It Cost
- Defining Your Needs in Relation to Your Skills, Budget, Practice, Firm Size
- Key Hardware and Software for Managing a Successful Practice
- Case Management and Analysis, Time Keeping, Billing
- Ethical Issues on Billing Your Clients - C.R.P.C. 1.5
- E-Filing
- Establishing a Web Presence - C.R.P.C. 7.1-7.5

- Online Research Tools
- Paperless Document Management
- Is Electronic Processing Necessary - Can You Function Without It? (Federal Ct. Filing Requirements, LexisNexis, E-Mail Communications)
- Data Storage
- Saving Money: Deals and What's Good and Bad

Presented by Phil Shuey, Esq.

12:15 pm **Lunch On Your Own**

1:30 pm

Bookkeeping Recordkeeping and Billing - When Will I Have Time!

- Maintaining Your Checking Accounts (*Trust v. Office*)
- Keeping a Check and Client Ledger
- Understanding a Balance Sheet and Income Statement
- Reports You Will Need to Prepare
- Am I Making Money Yet?
- Optimizing the Billing and Collection Cycle
- Outsourcing with A Bookkeeper or Accountant
- Meeting Trust Account Requirements (including COLTAF) and Recording Activity
- Credit Cards
- Keeping Track of Your Time
- Bills and Billing
- Account Reconciliation

Presented by daphne salone and Reba Nance

2:45 pm **Break**

3:00 pm

Marketing and Business Development - the Ying/Yang of Growing Your Business

- The Difference Between Marketing and Business Development
- Personal Branding
- The Marketing Wheel of Fortune
- Advertising, Public Relations and Sponsorships
- Web sites, Blogging, Facebook and Twitter
- Consultative Sales for Attorneys
- Relationship Management

Presented by Mark Beese

4:30 pm **Day 1 Adjourns**

8:00 am Registration & Continental Breakfast

- 8:30 am Office Sharing - Nuts and Bolts**
- Office Sharing vs. Executive Suites
 - Economic Considerations
 - Finding Good Candidates for Office Sharing
 - Space, Staffing and Technological Considerations
 - Use of Common Resources
 - Financial and Lease Agreements
 - Ethics Issues and Ethics Opinion No. 89
 - Confidentiality and Client Considerations
 - Avoiding the Involuntary Partner
- Presented by Erich Bethke, Esq. and Kristi River, Firm Administrator*

Practice Maintenance

- File Set-up, Review, Diligence
- Fee Agreements and Engagement Letters
- Diaries, Calendars, Tickling, Back-up
- Client Interviews
- Scope and Objective of Representation, Unbundled Tasks
- Informed Consent
- Working With Legal and Non-Legal Support Staff
- Use of Paralegals
- Inventorying and Support Systems
- Managing Your Time
- Bank Accounts and Ledger Systems
- Alleviating Client's Confidentiality Concerns
- Billing Discipline
- CBA Resources

Presented by Reba Nance

10:30 am Break

- 10:45 am Make A Business Plan**
- Importance of Having a Plan
 - Advantages of a Business Plan
 - Advantages of Budgeting
 - Financing the Start-Up Period
 - Tax Considerations
 - Evaluating Costs of Doing Business
 - Budgeting for the Start Up
 - Death and Taxes
 - Being an Employer and Employment Controls
 - Setting Billing Rates and Billing
 - Monitoring the Evolving Plan

Presented by Ronald L. Seigneur, CPA/ABV/CFF, CFA

12:00 pm Lunch On Your Own

- 1:15 pm Risky Business - Managing Your Malpractice Exposure**
- Malpractice Insurance
 - Recognizing and Avoiding Conflicts of Interest CRPC 1.7
 - How to Accept or Reject A Client CRPC 1.5
 - Scope of Engagement and Identifying the Client CRPC 1.2
 - Ways to Limit Your Liability
 - Ethically Networking for Competence
 - Asking For Help - Don't Dabble
 - Client Consent CRPC 1.0
 - Rules 1.1, 1.3, 1.5, 1.7, 1.8, 1.9, 1.10, 1.16, 1.18, 7.1, 7.2, 7.3, 7.4 and 7.5.
- Presented by David C. Little, Esq., David J. Graf, Esq., John M. Palmeri, Esq.*

- 2:00 pm Practical Application of the Rules of Professional Conduct**
Presented by David C. Little, Esq.

2:45 pm Break

- 3:00 pm Success Stories of Opening Your Own Law Practice**
- Success Stories, War Stories From Attorneys Who Have Opened Their Own Law Firm
 - Helpful Information To Open, Build and Benefit Your Practice
 - Sorting Through All the Advice You'll Be Given
 - Do's and Definite Don'ts
 - Rules 3.4, 4.1, 4.2, 4.3, 4.4 and 4.5.
 - You Ask 'Em Questions and Candid Answers From the Panel
- Presented by Marco Chayet, Esq., Frank Danzo, Esq., David J. Graf, Esq. and Martha Ridgway, Esq.*
Moderated by David C. Little, Esq.

4:30 pm Day 2 Adjourns

The CBA Economic Assistance Task Force is offering special pricing for CBA MEMBERS affected by the economy!

See registration form for details.

REGISTER ONLINE! Go to www.cobar.org/cle

HANGING YOUR SHINGLE 2009 - BY CHOICE OR CIRCUMSTANCE

1  **Register by PHONE...**
when using VISA or MasterCard.
In Denver: (303) 860-0608
Toll-Free: (888) 860-2531

2  **Or FAX form to...**
when using VISA or MasterCard.
FAX to: (303) 860-0624

3  **Or MAIL form to...**
CLE in Colorado
1900 Grant St, Suite 300
Denver, CO 80203-4303

4  **Or Register ONLINE...**
when using VISA or MasterCard.
Go to www.cobar.org/cle

LIVE PROGRAM / WEBCAST / VIDEO REPLAY ORDER FORM

The CBA Economic Assistance Task Force is offering special pricing for CBA MEMBERS affected by the economy!

INDIVIDUAL TUITION:

- Non-member:\$309
 CBA Member:~~\$269~~
 Economic Assistance to CBA Members Pricing:\$79

LIVE: AUGUST 13-14, 2009

(Please choose between the live program and live webcast)

- LIVE PROGRAM** - Denver: CBA-CLE Classroom, 1900 Grant St., Suite 300 (GP081310L)
 LIVE WEBCAST - Direct to your desktop (GP081310W)
Registrants who wish to participate via live webcast, must have access to a high-speed internet connection and to important e-mail instructions.

VIDEO REPLAYS: SEPTEMBER 2-3, 2009

- Denver:** CBA-CLE Classroom, 1900 Grant Street, Suite 300
 Colorado Springs: 421 S. Tejon Street, Suite 100
 Grand Junction: 1250 E. Sherwood Drive

LIVE PROGRAM / WEBCAST / VIDEO REPLAY TOTAL \$ _____

HOMESTUDY ORDER FORM:

To receive CLE credit, you must purchase both the course materials and the recorded seminar. Seminar recordings are available in CD format.

COURSE MATERIALS, & RECORDED SEMINAR (CD)

- CBA Member: \$79 Non-member: \$309

Price \$ _____
 Shipping & Handling \$ 10.00
 Subtotal \$ _____
 Applicable Sales Tax \$ _____

(7.72% Denver, 4.1% RTD and 2.9% rest of Colo.)

HOMESTUDY SUBTOTAL \$ _____

Name(s) _____

Attorney Reg. No. _____

Firm/Organization _____

E-Mail Address _____

Street Address _____

City _____

State _____ Zip _____

Telephone () _____

Fax () _____

PAYMENT METHOD:

- Enclosed is my check made payable to **CBA-CLE**
 VISA MasterCard

Credit Card # _____

Exp. Date _____

Signature _____

Required for credit card orders

ALL REGISTRATIONS MUST INCLUDE A CHECK OR CHARGE CARD INFORMATION.

CLE Use Only:

Check # _____ Approval #: _____

WEBCAST INFORMATION:

Course materials are provided in electronic format to all web cast attendees. For individuals who prefer to receive the materials in paper form, you must make this request at the time of registration. Once CBA-CLE has final materials prepared, they will be shipped immediately upon your request, but we cannot guarantee that you will receive them prior to the program.

TIPS FOR A BETTER WEBCAST EXPERIENCE:

- Your computer should have a 500 mhz or higher processor and at least 128 megs of RAM.
- Hi-Speed connection - Viewers with faster and more consistent connections will have a better viewing experience.

PLEASE RUN THIS TEST TO MAKE SURE YOUR COMPUTER MEETS THE MINIMUM SYSTEM REQUIREMENTS:

http://www.cobar.org/cle/photos/CLE_webcast_test.html

To view webcasts and streaming videos your computer must meet some minimum system requirements. The videos are best viewed using

Microsoft's Windows Media Player™. You will need to have Windows Media Player v.7 or higher installed. If you have a newer PC you probably already have the player installed as part of the Windows operating system. If you're running an older PC, or if you use a Macintosh, you will need to download and install the player. Here is a link to the Microsoft Media Player website to help you determine which version of Media Player is right for your computer.

[http://www.microsoft.com/windows/windowsmedia/download/All Downloads.aspx?displang=en&qstechnology=](http://www.microsoft.com/windows/windowsmedia/download/AllDownloads.aspx?displang=en&qstechnology=)

IMPORTANT - DO YOU HAVE A FIREWALL OR ROUTER?

It is possible that your firewall may block the stream or that your router may not pass the stream correctly. Try temporarily disabling the firewall to see if the stream works or have your network administrator look into it.

Additional information and instructions regarding connecting to the webcast will be e-mailed to you approximately 1-5 business days before the webcast.



Colorado Bar Association CLE

The nonprofit educational arm of the Colorado Bar Association and the Denver Bar Association

1900 Grant Street, Suite 300, Denver, Colorado 80203-4303

Nonprofit Org.
U.S. Postage Paid
Permit No. 1638
Denver, CO

HANGING YOUR SHINGLE 2009 -

BY CHOICE OR
CIRCUMSTANCE

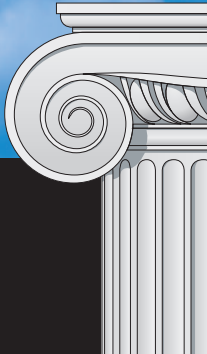

LIVE PROGRAM AND LIVE WEBCAST:

AUGUST 13-14, 2009

VIDEO REPLAYS: **SEPTEMBER 2-3, 2009**

REGISTER ONLINE! Go to www.cobar.org/cle

HANGING YOUR SHINGLE 2009 -

BY CHOICE OR
CIRCUMSTANCE



Co-sponsored with the Professional Liability Committee and the Solo & Small Firm Section of the Colorado Bar Association

LIVE PROGRAM AND LIVE WEBCAST: AUGUST 13-14, 2009

Live program will be held at the CBA-CLE Classroom, 1900 Grant Street, Suite 300, Denver, CO

VIDEO REPLAYS: **SEPTEMBER 2-3, 2009** • Denver, Colorado Springs, and Grand Junction



Submitted for 15 General Credits, including 3 Ethics